

REMOTE POWERING Central Energy System (HUB)

User Guide

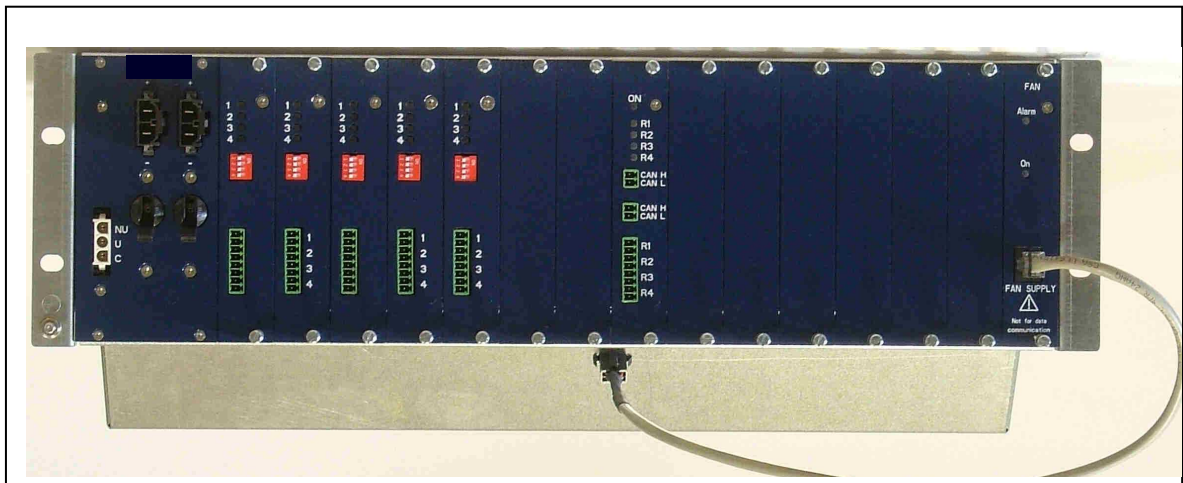

Content

RECTIFIER SYSTEM - USER MANUAL

The information and pictures within this Manual is believed to be true at the time of publication however Mitra E&I accepts no responsibility to consequences from printing errors or inaccuracies. The information, pictures, drawings and specifications contained herein are subject to change without notice

CHAPTER 1 DESCRIPTION OF THE SYSTEM.....	5
1.1 References.....	5
1.2 Accessories not delivered with the basics systems	6
CHAPTER 2 MECHANICAL	7
2.1 Packaging tbd	7
2.2 Dimensions, weight tbd.....	7
CHAPTER 3 : ELECTRICAL	9
3.1 General.....	9
3.1.1 Environmental Information	9
3.1.2 Safety of the system & assessments.....	9
3.2 Input	10
3.3 Outputs.....	10
3.4 Up converters.....	11
3.5 Fan supply unit.....	12
3.6 Environmental conditions	12
CHAPTER 4	13
4.1 Connections and Settings.....	13
4.1.1 DC Input.....	13
4.1.2 DC Line Output.....	14
4.1.3 Alarm Output	17
CHAPTER 5 INSTALLATION PROCEDURE.....	20

5.1	Rack mounting	20
5.1.1	Grounding.....	20
5.1.2	Convection cooling	20
5.1.3	Fan cooling – with fan unit.....	21
5.1.3.1	Mounting or Replacement of the fan unit.....	21
5.1.3.2	Mounting of one rack with fan unit.....	22
5.1.3.3	Stacked mounting of racks with fan unit	23
5.1.4	Mounting of ETSI brackets.....	24
5.2	Mounting of the units.....	25
5.2.1	Mounting and place of the units.....	25
5.2.2	Fan Supply Unit.....	25
5.2.3	Up converter	26
5.2.4	Controller CEM03	26
5.2.5	Blank panel	26
5.3	Connections.....	27
5.3.1	Grounding.....	27
5.3.2	Controller CEM03	27
5.3.3	Alarms.....	28
5.3.4	Line Outputs.....	29
5.3.5	DC Inputs.....	31
5.3.6	Safety of the system & assessments	32
CHAPTER 6	USE OF THE SYSTEM.....	33
6.1	Settings – Normal operation.....	33
6.3	Replacement of units.....	37
6.3.1	Replacement DC/DC converter.....	37
6.3.2	Replacement of the Controller CEM03.....	37
4.1.1	Replacement Fan Supply	37
CHAPTER 7	SHORT FORM INSTALLATION MANUAL.....	38

7.1	General.....	38
7.1.1	Safety.....	38
7.1.2	Dimensioning of the Remote system	38
7.2	Installation procedure and check list.....	39
Table 1 :	references of the system	5
Table 2 :	dimensions , weight.....	7
Table 3 :	up converter – specifications.....	11
Table 4 :	colour code Lex Multicable feeder.....	16
Table 5 :	alarm table - contacts	18
Table 6 :	alarm conditions	35
Table 7 :	overview Alarms - Leds	36
Figure 1 :	Packaging – box.....	7
Figure 2 :	Front view – 19” – typ. configuration with fan tray	8
Figure 3 :	DC/DC Up converter – output characteristic.....	11
Figure 4 :	supply of fan tray.....	12
Figure 5 :	DC input connector / alarms.....	13
Figure 6 :	DC input cable & Ground	14
Figure 7 :	Line output.....	15
Figure 8 :	Lex Multicable feeder	15
Figure 9 :	alarm connector.....	17
Figure 10 :	alarm cable.....	19
Figure 11 :	convection cooling.....	20
Figure 12 :	one rack with fan unit	22
Figure 13 :	stacked mounting of units with fan tray.....	23
Figure 14 :	ETSI mounting brackets.....	24
Figure 15 :	Grounding.....	27
Figure 16 :	alarm outputs.....	28
Figure 17 :	alarm table – system level.....	29
Figure 18 :	Line outputs.....	30
Figure 19 :	DC/DC output characteristic – per line.....	31
Figure 20 :	input DC external protection.....	32
Figure 21 :	Up converter	33
Figure 22 :	CEM03 controller.....	34
Figure 23 :	alarm status CEM03 removed.....	37

CHAPTER 1 DESCRIPTION OF THE SYSTEM

1.1 References

Reference & Ordering code	Description	Content
CER48/00L320RFW-2A	Basic system : HUB or Central Energy Rack without fan tray	Empty rack Dual DC input card
CES48/06L320RFM-2F	Basic System with fan tray , one monitor and 6 quad Up converters	CER48/00L320RFW-2A : 1x CEC4L320 : 6x CEM03 : 1x CO4489/50 : 1x CO4489/51 : 1x blind panel : 7x
CES48/12L320RFM-2F	Basic System with fan tray, one monitor and 12 quad Up converters	CER48/00L320RFW-2A : 1x CEC4L320 : 12x CEM03 : 1x CO4489/50 : 1x CO4489/51 : 1x blind panel : 1x
CEC4L320	Quad Up converter	Par 10 tbd
CEM03	Monitoring for 4 remote sites / up to 24 lines per site	
CO4489/51	Fan supply card	
CO4489/50	Fan tray with supply cable	
CO4489/52	Fan kit	CO4489/50 : 1x CO4489/51 : 1x
5304 500 00711	Blind panel for empty converter place (box of 10 panels)	10 panels with fixing screws
5304 500 35001	RP Lex Multicable feeder dual	
5304 500 00961	Communication mating connector	50 connectors 2-pole
5304 500 00731	Kit Alarm and DC input cables	
5304 500 00691	ETSI mounting kit	bracket 2x spring washer M6 4x washer M6 4x M6x12 screw T30 4x

Table 1 : references of the system

1.2 Accessories not delivered with the basics systems

Note : these accessories are NOT part of the CES and CER systems described in the section 1.1.
The accessories have to be ordered separately.

Ordering code	Description	Content		
5304 500 00711	Blind panel	10x Blind panel with fixing screw		
5304 500 35001	RP Lex Multicable feeder dual			
5304 500 00961	Communication mating connector	50 x 2-pole screw connectors		
5304 500 00721	DC Up 4 pairs	1 box 50 x tbd		
5304 500 00731	Kit Alarm and DC input cables	2 x DC Input cables with connector 1 x Alarm cable with connector		
5304 500 00691	ETSI mounting kit	bracket 2x spring washer M6 4x washer M6 4x M6x12 screw T30 4x		
No reference	Grounding cable			

CHAPTER 2 MECHANICAL

2.1 Packaging tbd

Paperboard Box : H x W x D (210 x 600 x 410)mm tbd
Weight typ. tbd kg

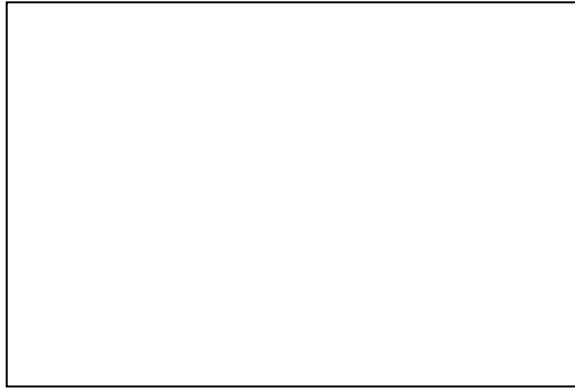

Figure 1 : Packaging – box

2.2 Dimensions, weight tbd

Unit	W x H x D (mm)	Weight (kg)	Quantity	Total (kg)
Empty rack 19" without fan tray	483 x 167 x 247	3.9 tbd		
Empty rack 19" with fan tray	483 x 133 x 247	4.1 tbd		
DC/DC UP converter	25 x 130 x 235	0.33	1 .. 12	
Monitor card CEM03	25 x 130 x 235	0.18	1 .. 4	
Fan control unit	25 x 130 x 235	0.23	1	
Fan tray	tbd	tbd	1	
			Total	
			Max.	

Table 2 : dimensions , weight

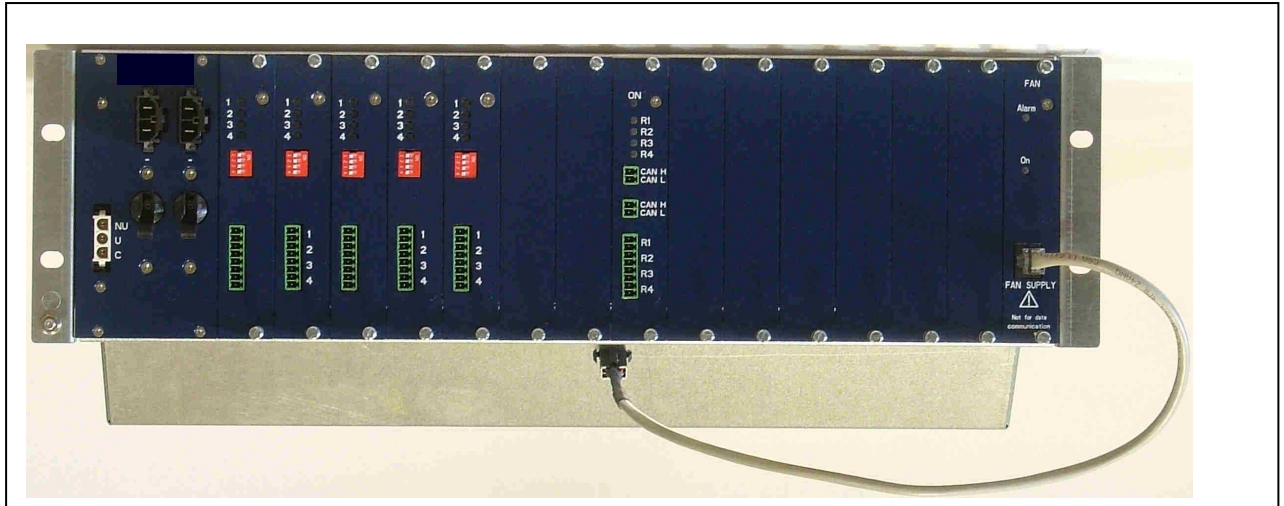



Figure 2 : Front view – 19" – typ. configuration with fan tray

CHAPTER 3 : ELECTRICAL

3.1 General

3.1.1 Environmental Information

- 1 The equipment that you bought has required the extraction and use of natural resources for its production. It may contain hazardous substances for the health and the environment.
- 2 In order to avoid the dissemination of those substances in our environment and to diminish the pressure on the natural resources, we encourage you to use the appropriate take-back systems. Those systems will reuse or recycle most of the materials of your end life equipment in a sound way.
- 3 The crossed-bin symbol  invites you to use those systems.
- 4 If you need more information on the collection, reuse and recycling systems, please contact your local or regional waste administration.
- 5 You can also contact us for more information on the environmental performances of our products.

3.1.2 Safety of the system & assessments

- a) The voltage of the RFT-C circuit is 320 VDC.
- b) The effective line output capacitance of the Feeder is :
 - between the connection points for the conductor of the TELECOMMUNICATION NETWORK : typically 220nF
 - between the connection point for the one conductor of the TELECOMMUNICATION NETWORK and earth : typically 4nF
- c) At the time of installation, a system assessment shall be carried out to ensure that the effective capacitance of the total system, including the capacitance of the Feeder, does not exceed the values specified in EN60950-21 Figure 3.
- d) At the time of installation, it shall be checked that the voltage rating of the wiring of the TELECOMMUNICATION NETWORK is adequate for the normal RFT-C CIRCUIT voltage (320VDC)
- e) At the time of installation, it shall be checked that the circuits to be connected together are all RFT-C CIRCUITS.

3.2 Input

Input voltage : nominal 54V DC (40 ...72V DC)

Current : max. 30A (14 DC/DC at 40V input)

Protections : breaker in each DC input
UVP
polarity (each input has a series diode in the “-“ DC Bus)

	min	typ.	max	Unit	Notes
Input Voltage	40	54	72	Vdc	
UVP		30		Vdc	Turn On : max. 34V
Input current		0.41		Adc	per converter at 54V 4 converters per unit
Input current			0.625	Adc	per converter at 40V
Total input current		21 A		Adc	at 54 V input and 14 DC/DC units (56 lines)
Total input current			30 A	Adc	at 36 V input and 14 DC/DC units (56 lines)
Input protection		40		A	Breaker in each DC input
Temperature	0		+30	°C	Convection cooling : temperature measured 20mm under the rack
Temperature	0		+ 55 tbd 45	°C	Fan cooling : Temperature of incoming air measured 20mm before the air inlet

3.3 Outputs

DC out : per line **320V DC / 58mA nominal current**
maximum 60mA

Description : the line DC circuit is a RFT-C voltage

Lines out: 4 lines per Up converter
up to 56 lines
up to 4 remote site per monitor card

Line cables : minimum rating of 320V DC

Protections: see fig. 3
leakage current < 1.5mA
UVP 245V : current limitation is ≤ 8mA down to 166V
Open line : max. 50V and 58mA

Communication : Alarms : **U**rgent (U) and **NU** (NU) alarm contacts

3.4 Up converters

One converter unit contents 4 line converters of 18W

Power : 18W per line converter

Description	min	typ.	max	Unit	Note
Voltage	312	320	328	V dc	
Efficiency	83	85		%	54V , nominal load
Current			58	mA dc	per converter (4 per unit)
Undercurrent			0.1	mA dc	detection open pair tbd
Open line voltage			50	V	
Open line current			58	mA dc	
UVP		245		V dc	detection pair in short-circuit
Leakage current			5	μ A dc	per converter
Temperature	0		+55	$^{\circ}$ C	
Screw terminal		0.05		mm ²	
		24		AWG	

Table 3 : up converter – specifications

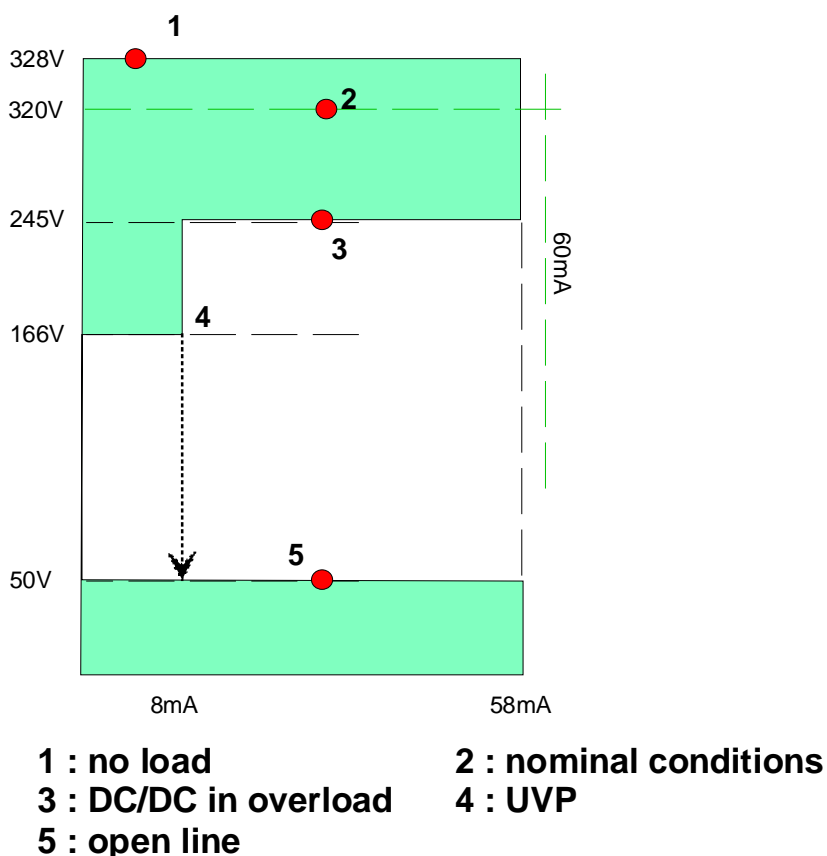

Figure 3 : DC/DC Up converter – output characteristic

3.5 Fan supply unit

Important Warnings

**The Fan Cable must be immediately connected to the Fan card.
There is a risk of overheating if the fan tray is not supplied when
fixed under the Rack**

**The Fan Card Front Connector (RJ45) can only be used for
Fan Tray supply and may NOT be used for
Data Communication (Ethernet,...) :
The supply voltage (4 x 10V DC 180mA) for the fans is present on
this RJ45 connector**

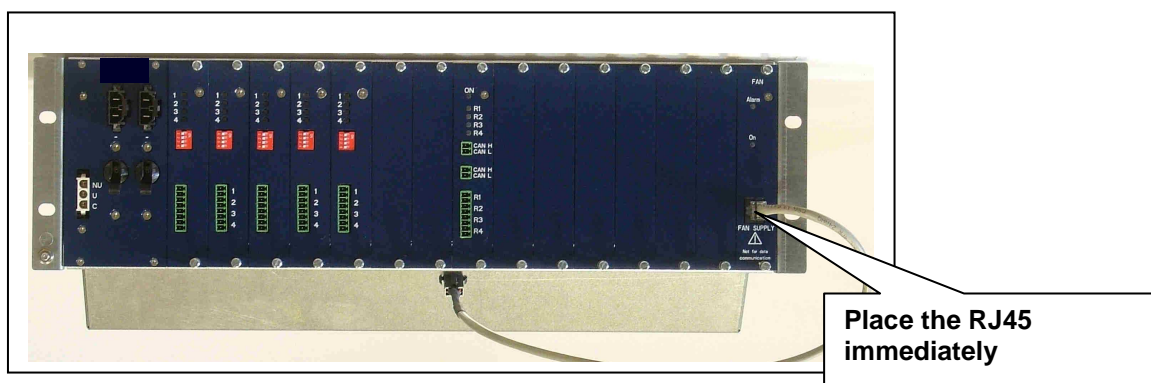

Figure 4 : supply of fan tray

3.6 Environmental conditions

Temperature :	0 .. +55°C tbd	with fan cooling
	0 .. +30°C	convection cooling
Cooling :	Fan cooling (fan unit mounted under the rack)	
	Convection cooling	
Humidity :	5 ..95%RH , no condensation	
Environment :	controlled	
Altitude (operating)	2 200m	
Maximum dissipation	150W	

CHAPTER 4

4.1 Connections and Settings

4.1.1 DC Input

Connector Type on the Rack:

Molex Mini-Fit , Sr Reference : 42816 - 0212

Connector Type for the client DC source :

Molex Mini-Fit , Sr Female Reference : 42816 – 0011

5304 500 00731	RP Lex 54V Input cable kit DC input cable with connector : 2x Alarm cable with connector
----------------	--

Current : max. 30A at 40 V
Protection : 40A breaker in each “-“ DC line
Wire: AWG 10
Polarity : protected for inverse polarity (series diode)

INPUT UNIT

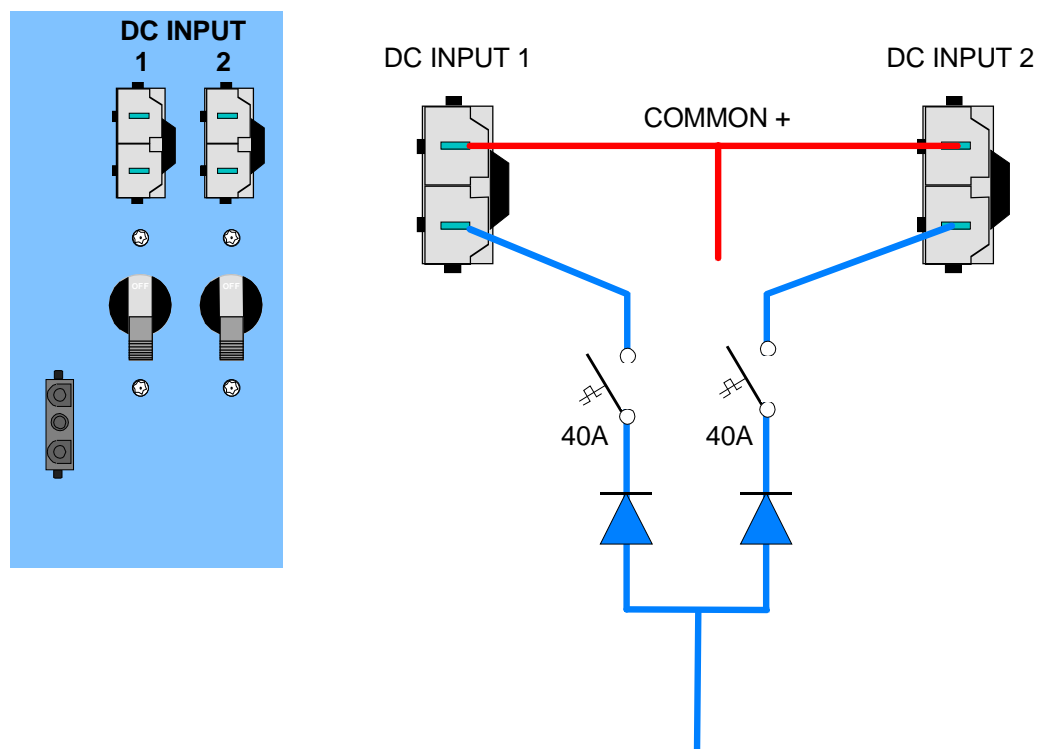

Figure 5 : DC input connector / alarms

4.1.1.1 DC input cable

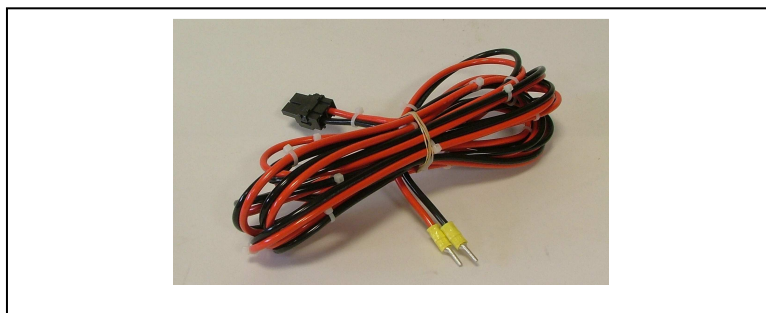

Figure 6 : DC input cable & Ground

See also table 1 :

5304 500 00731	RP Lex 54V DC Input cable part of the kit
----------------	--

Length :	4 m total	Cross-section :	AWG10
System side :	Molex-mini-Fit 2 pole	Application side :	pin tag AWG12-10
Colour :	1 : Negative = BLACK 2 : Positive = RED		

4.1.2 DC Line Output

* Connector :

Connector Type on the Rack: PHOENIX MC 1.5/8 – G - 3.5 (ref:18 44 27 8)

Connector Type for the client application : PHOENIX MC 1.5/8-ST - 3.5 (ref : 18 40 42 1)

Wire connection :	screw terminals
cross-section :	AWG28 .. 16 / 0.08 .. 1.5 mm ²

* Power : 18W per dc/dc up converter
current : 58mA

* Polarity: see fig. 7

the “+” and “-” are FLOATING

* Protections :
see fig. 7

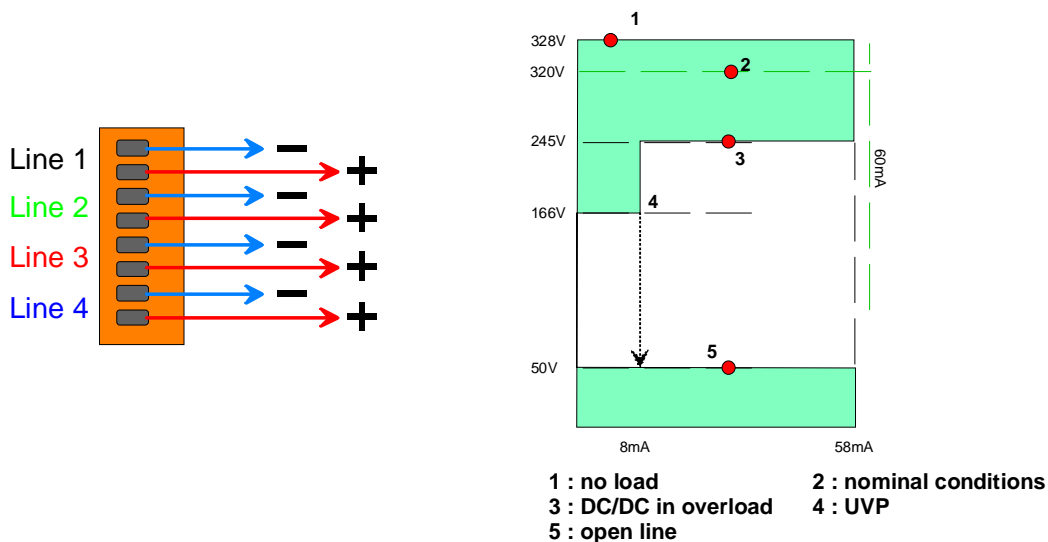

Figure 7 : Line output

4.1.2.1 Line Output cable

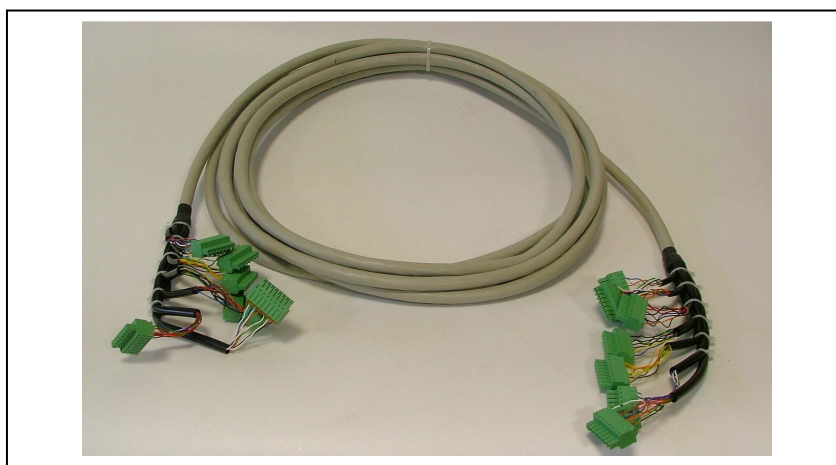

Figure 8 : Lex Multicable feeder

See also table 1 :

5304 500 35001	RP Lex Multicable feeder dual
----------------	-------------------------------

Length : 6 m Cross-section AWG24 – single strand
 the cable MUST be cut in the middle depending on the application
 System side : PHOENIX MC 1.5/8-ST - 3.5 Application side : no terminal

Colour : see table 4

LEFT OF FEEDER/RIGHT OF BLOC			RIGHT			
	a	b		a	b	
C1P1	White	blue		White	blue	
C1P2	White	orange		White	orange	
C1P3	White	green		White	green	
C1P4	White	brown		White	brown	
C2P1	White	grey		C9P1	White	grey
C2P2	red	blue		C9P2	red	blue
C2P3	red	orange		C9P3	red	orange
C2P4	red	green		C9P4	red	green
C3P1	red	brown		C10P1	red	brown
C3P2	red	grey		C10P2	red	grey
C3P3	black	blue		C10P3	black	blue
C3P4	black	orange		C10P4	black	orange
C4P1	black	green		C11P1	black	green
C4P2	black	brown		C11P2	black	brown
C4P3	black	grey		C11P3	black	grey
C4P4	yellow	blue		C11P4	yellow	blue
C5P1	yellow	orange		C12P1	yellow	orange
C5P2	yellow	green		C12P2	yellow	green
C5P3	yellow	brown		C12P3	yellow	brown
C5P4	yellow	grey		C12P4	yellow	grey
C6P1	white blue	blue		C13P1	white blue	blue
C6P2	white blue	orange		C13P2	white blue	orange
C6P3	white blue	green		C13P3	white blue	green
C6P4	white blue	brown		C13P4	white blue	brown
C7P1	white blue	grey		C14P1	white blue	grey
C7P2	red blue	blue		C14P2	red blue	blue
C7P3	red blue	orange		C14P3	red blue	orange
C7P4	red blue	green		C14P4	red blue	vert

Table 4 : colour code Lex Multicable feeder

4.1.3 Alarm Output

* Connector

Connector Type on the Rack:

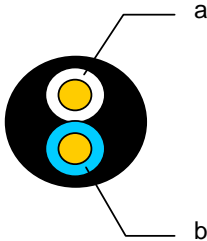
Mate-N-Lok 3pole male (plug)

Connector Type for the client application :

Mate-N-Lok 3pole female (bush)

Reference housing : 0 – 0350766 – 1

Reference socket (3 x) : 0 – 0350689 – 1 (for AWG24 – 18)

Cross-section : AWG28 .. 20 / 0.08 .. 0.5 mm²

See also table 1 :

5304 500 00731	RP Alarm cable part of the kit
----------------	---------------------------------------

I : tbd

Pin assignment:

- 1 : **C** = **C**ommon
- 2 : **U** = **U**rgent alarm
- 3 : **NU** = **N**on **U**rgent alarm

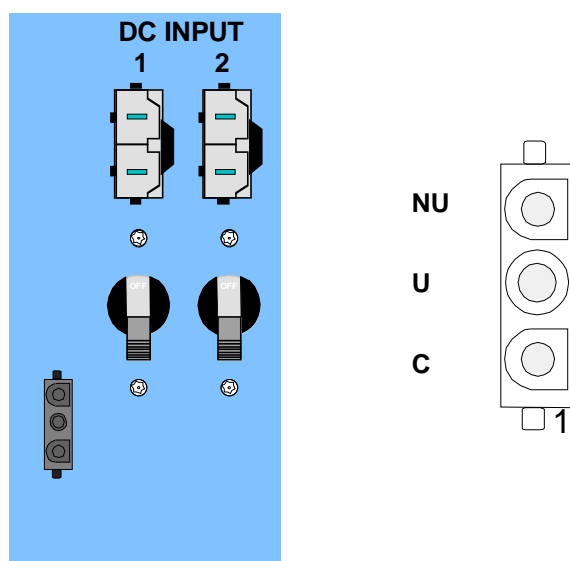

ALARM CONNECTOR

Figure 9 : alarm connector

Type alarm :

Voltage free contacts

Contact specifications : max. 72V dc / max. 0.3A dc / resistive load

Grounding : the Common of the alarm contacts is internally connected to the ground

Alarm table :

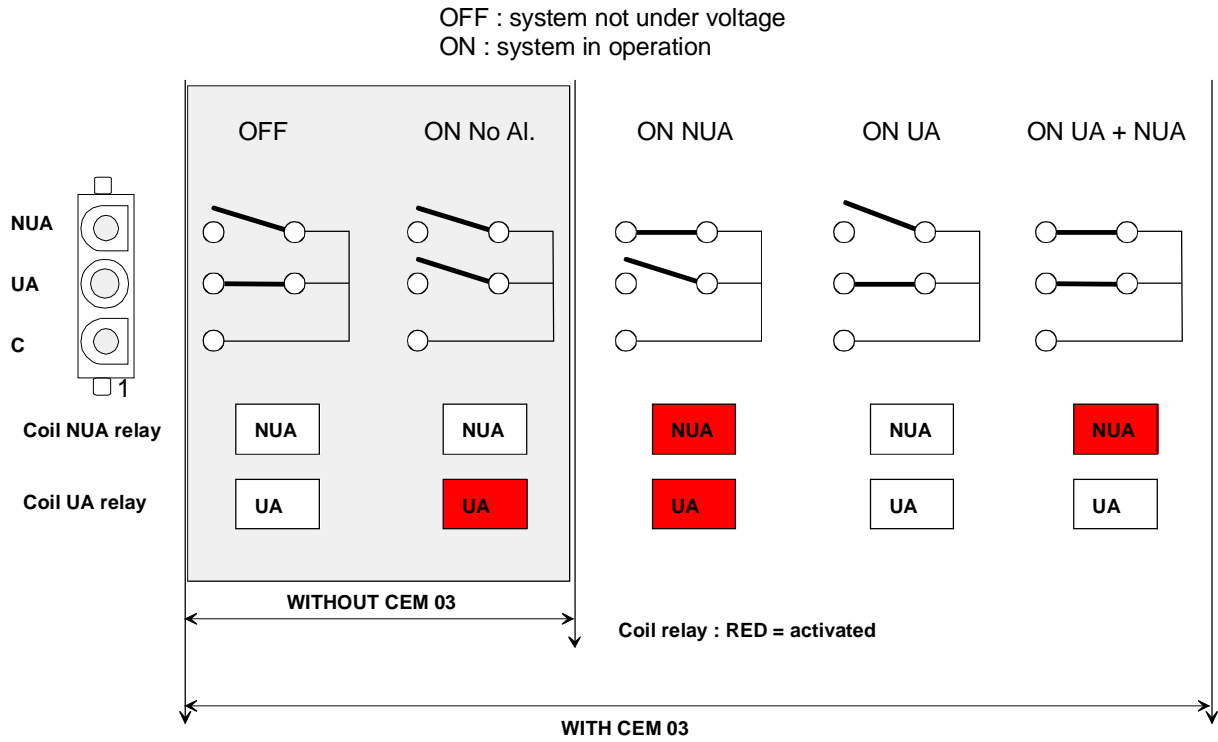

Table 5 : alarm table - contacts

CHAPTER 5 INSTALLATION PROCEDURE

5.1 Rack mounting

5.1.1 Grounding

The rack has to be connected to the ground (bonding) via its metal housing
 The grounding has to be in accordance with the local rules and specifications.
 See section 5.3 for the details

5.1.2 Convection cooling

Temperature : maximum +35°C tbd

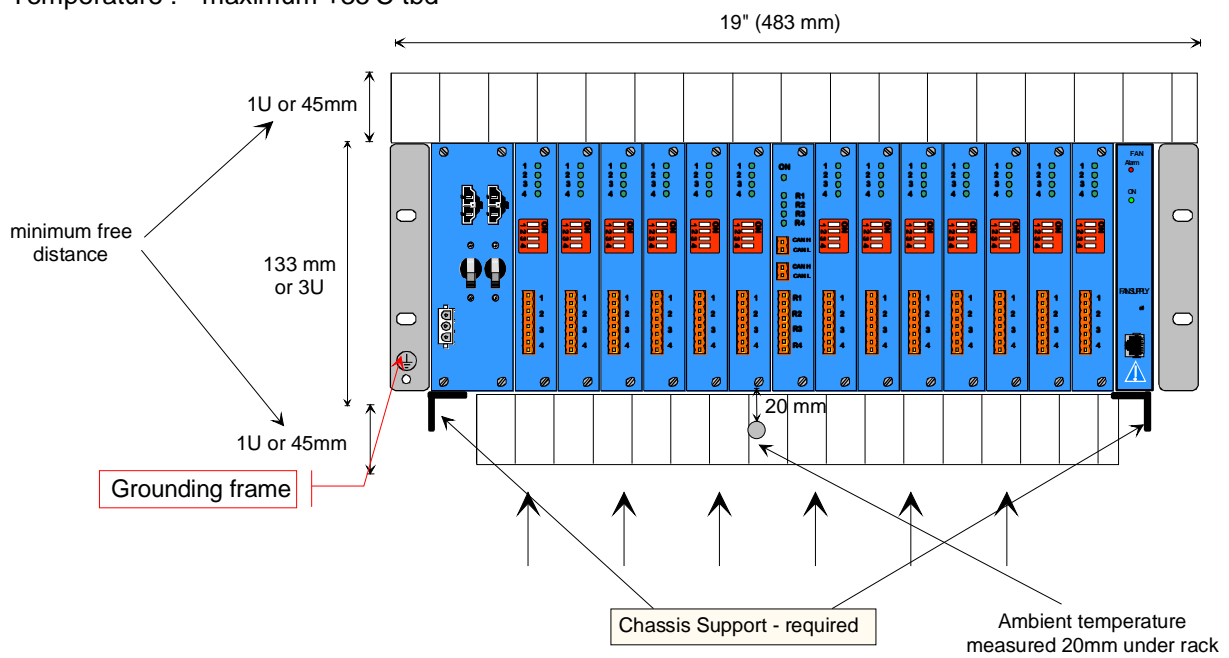

Convection cooling

Figure 11 : convection cooling

5.1.3 Fan cooling – with fan unit

5.1.3.1 Mounting or Replacement of the fan unit

Required material : see table 1

CO4489/52	Fan kit	CO4489/50 : 1x CO4489/51 : 1x
-----------	---------	----------------------------------

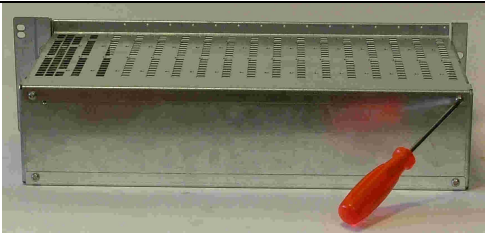
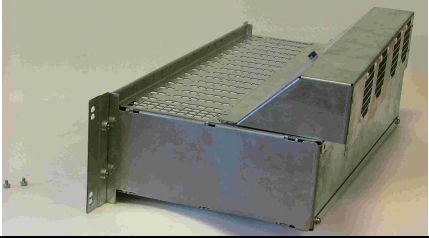
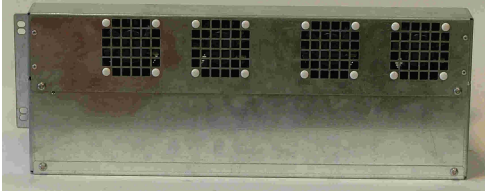
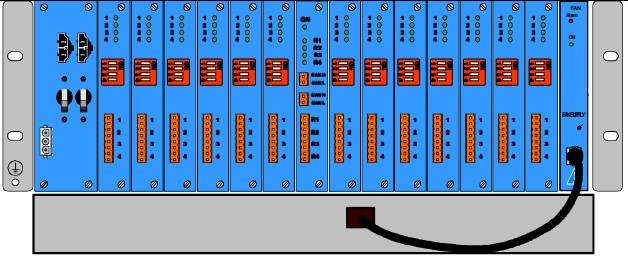
Description	Material	Picture
Rear of the rack, remove two combi-screws M4x8	Torx T20	
Place the fan unit		
Fix the unit with the two combi-screws M4x8		
Remove the most right blind panel and place the fan supply card		
Connect the fan unit with the fan supply card		

***When the Fan tray is installed, the Fan Cable must be immediately connected to the Fan card.
There is a risk of overheating if the fan tray is not supplied when fixed under the Rack***

The Fan Card Front Connector (RJ45) can only be used for Fan Tray supply and may NOT be used for Data Communication (Ethernet,...) : the supply voltage (4 x 10V tbd DC 180mA) for the fans is present on this RJ45 connector.

5.1.3.2 Mounting of one rack with fan unit

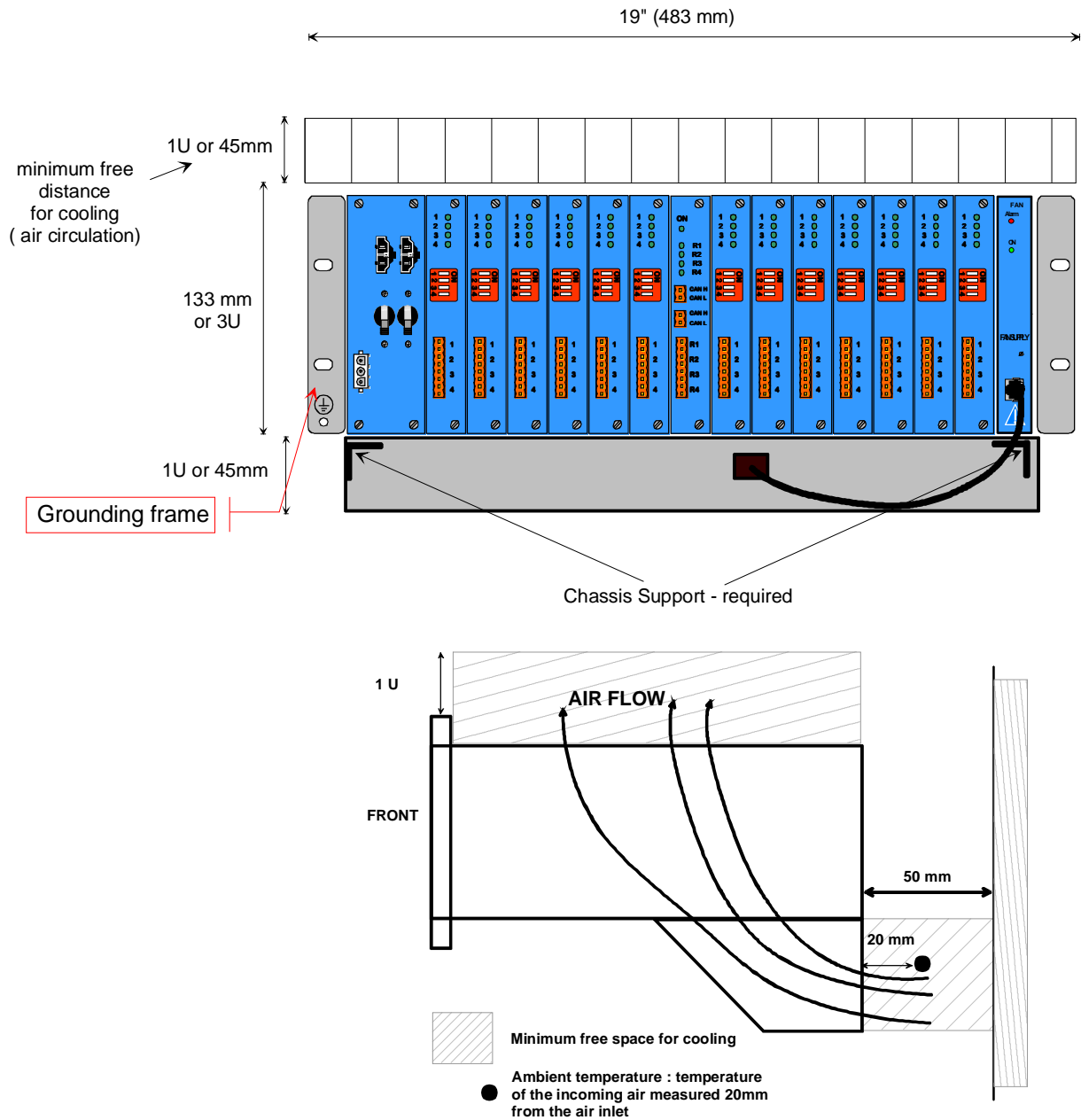

Figure 12 : one rack with fan unit

5.1.3.3 Stacked mounting of racks with fan unit

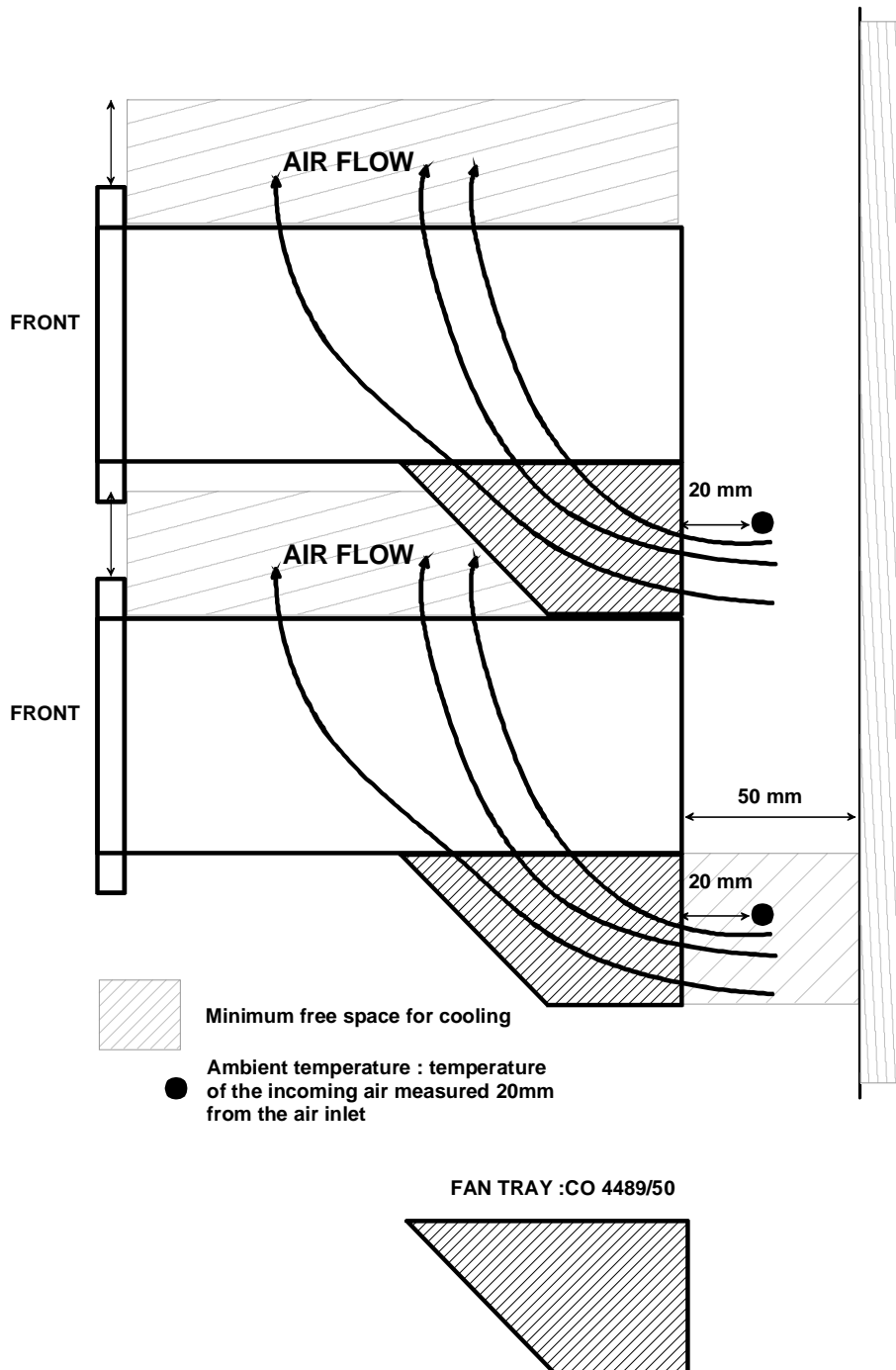

Figure 13 : stacked mounting of units with fan tray

The distance between the racks can be defined by the dimension of the fan tray mounted on the rack. The ambient temperature of each individual rack is the temperature of the incoming air measured 20mm from the air inlet.

5.1.4 Mounting of ETSI brackets

Reference of the kit : 5304 500 00691

Width : rack is delivered for 19" mounting
rack is also designed for ETSI mounting
accessories for ETSI mounting can be added
Free space top and rear : see figure 14

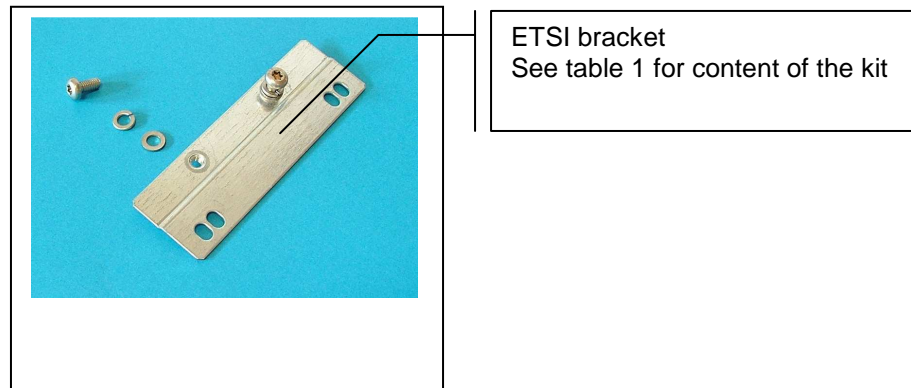

Figure 14 : ETSI mounting brackets

5.2 Mounting of the units

On delivery :
 rack for 19"
 empty rack

Settings must be done by the user.

All connections are on the front of the system and are accessible without any dismantling.

5.2.1 Mounting and place of the units

Except the input unit (most left) , all other units (Up converters , controllers , Fan Unit) have NO fixed place .

In total 15 units can be mounted in the rack.

For Safety reason , the empty places must be protected by a blind panel.

5.2.2 Fan Supply Unit

- Indications :
 - Red Led Alarm one or more fan in failure
 - Green Led On unit is operating
- Advised location : most right place as this unit have no direct relation with all other units
- Hot pluggable
- Connection with the fan tray : RJ45 on the front panel
 FAN SUPPLY
 Not for data Communication
- The Fan Card Front Connector (RJ45) can only be used for Fan Tray supply and may NOT be used for Data Communication (Ethernet,...) :
 the supply voltage (4 x 10V tbd DC 180mA) for the fans is present on this RJ45 connector.
- When the Fan tray is installed, the Fan Cable must be immediately connected to the Fan card.
 There is a risk of overheating if the fan tray is not supplied when fixed under the Rack
- Fixed by two screws

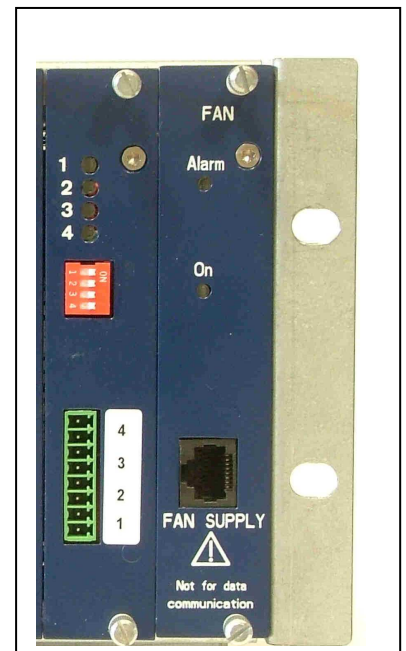

5.2.3 Up converter

- One up converter unit has 4 up converters
- Hot pluggable
- Open line voltage : max. 50V DC
- Nominal values :
 - voltage : 320V DC
 - current : 58mA
 - power : 18W
- Indications : one green Led per up converter
- Setting : dip-switch one position per converter
- Place : no dedicated place but for a better understanding of the application, it is recommended to place the converters of a same Remote site close to each other and close to the controller which monitor the site
- Fixed by two screws



5.2.4 Controller CEM03

- No dedicated place in the rack
- Recommended : place the controller as close as possible to the up converter unit for the relevant sites
- For details of the settings : refer to section tbd
- Up to 4 controller per rack : one Master and three Slaves
- One controller : can monitor up to 4 Remote sites
- Hot pluggable
- The system will continue to work without controller but alarms and defaults are no more detected
- Indications : one green Led per Remote site
- Fixed by two screws



5.2.5 Blank panel

- **For Safety reason , the empty places must be protected by a blind panel.**

5.3 Connections

5.3.1 Grounding

The grounding cable is NOT delivered with the system

Requirements :

- colour : yellow/green
- cross-section : 4mm² - length :
- terminal : M5 cable terminal which can be fixed on the left side of the rack , see figure 15 .

This cable MUST be connected to the frame containing the system

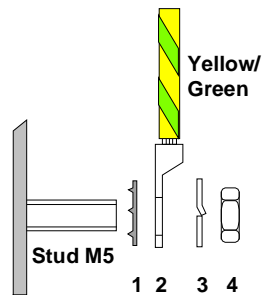

Stud M5 on the system

- 1 : M5 Earth washer
- 2 : M5 cable terminal
- 3 : spring washer
- 4 : M5 nut

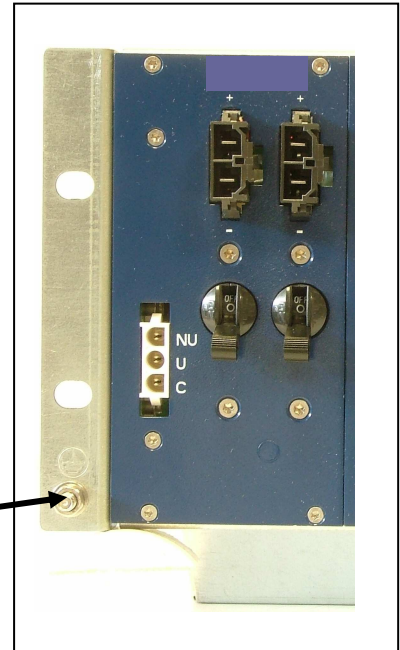

Figure 15 : Grounding

5.3.2 Controller CEM03

- R1 – R2 – R3 – R4
Twisted pair coming from the controller of the corresponding remote site
- CAN H and CAN L : will be required when the “Comp@s” communication is used



5.3.3 Alarms

- The alarm cable is NOT delivered with the system
- Alarm connector is hot-pluggable
- Type of alarm contacts :
the contacts are CLOSED when the corresponding alarm is present.
- Important :
as normally open contacts are used , a bad contact, a missing connection or a removed connector will NOT give any alarm
- The common is internally connected to the ground = 0V DC

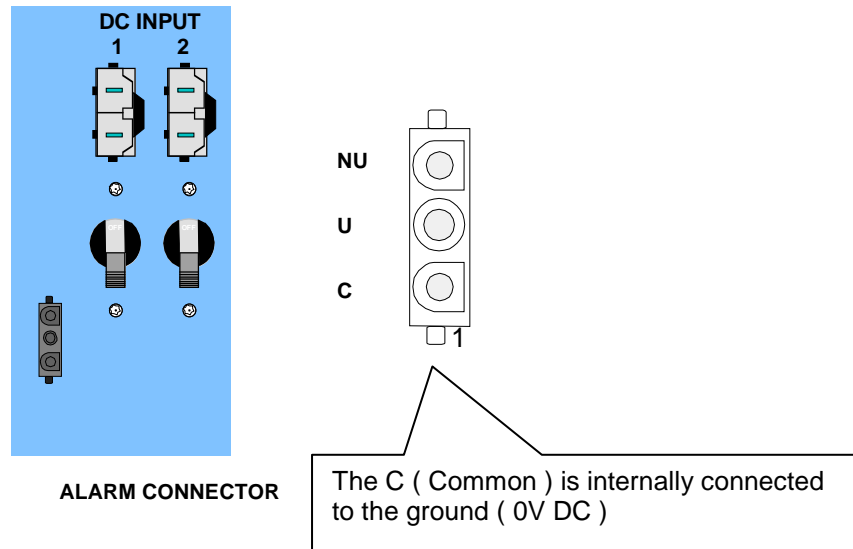

Figure 16 : alarm outputs

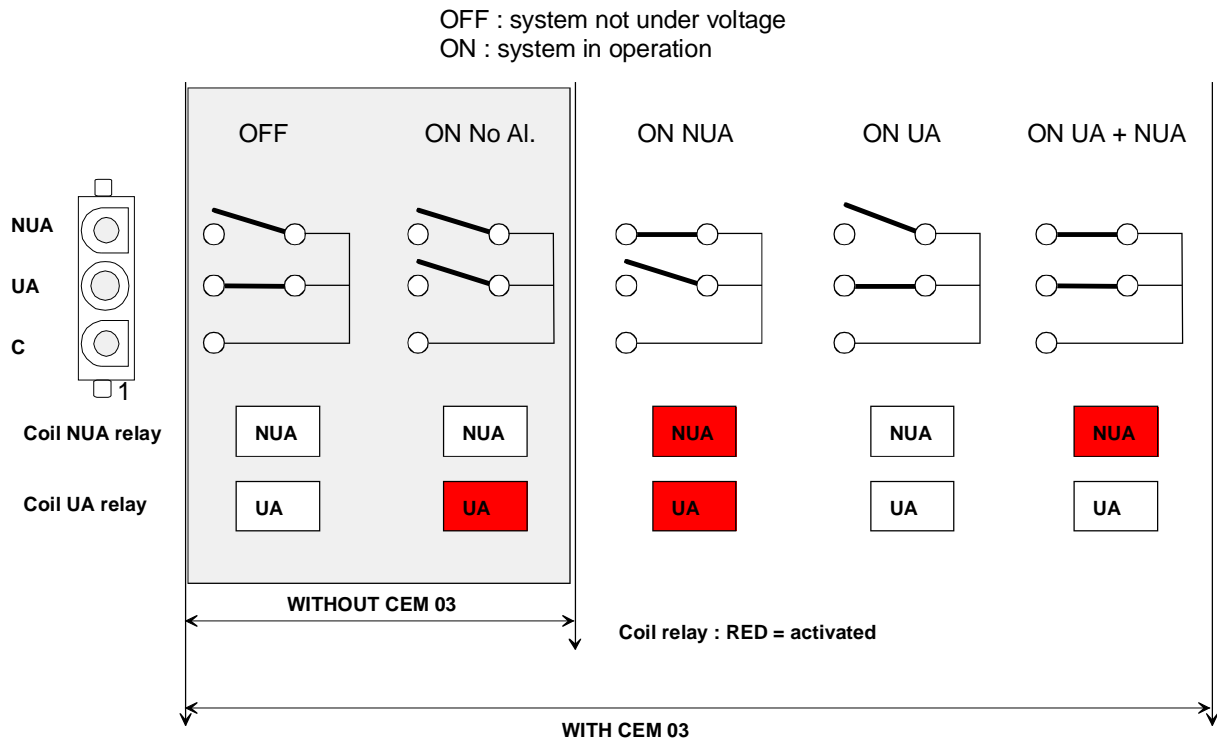

Figure 17 : alarm table – system level

Comments :

1. Without controller CEM03 the alarm contacts are as given by the fig. 17 and these contacts are not monitored by the controller : this is a fixed configuration.
The Urgent Alarm will be closed if the DC supply of the system is absent.
2. System with CEM03 and NO alarm : contacts UA and NUA are OPEN

5.3.4 Line Outputs

Total available slots = 15

Up to 4 Remote sites (ROP) can be connected to one Controller CEM03 of the Central Office rack .

Up to 4 (one Master and three Slaves) controllers can be used in one rack

Each Up converter unit has four converters

Each line can deliver : 58mA and max. 18W

The available power at the end is depending on the losses between the up and the down converter.

Controller	Remote sites	Fan Y / N	Available slots for up converters	Max lines
1	Up to 4	N	14	56
1	Up to 4	Y	13	52
2	Up to 8	N	13	52
2	Up to 8	Y	12	48
3	Up to 12	N	12	48
3	Up to 12	Y	11	44
4	Up to 16	N	11	44
4	Up to 16	Y	10	40

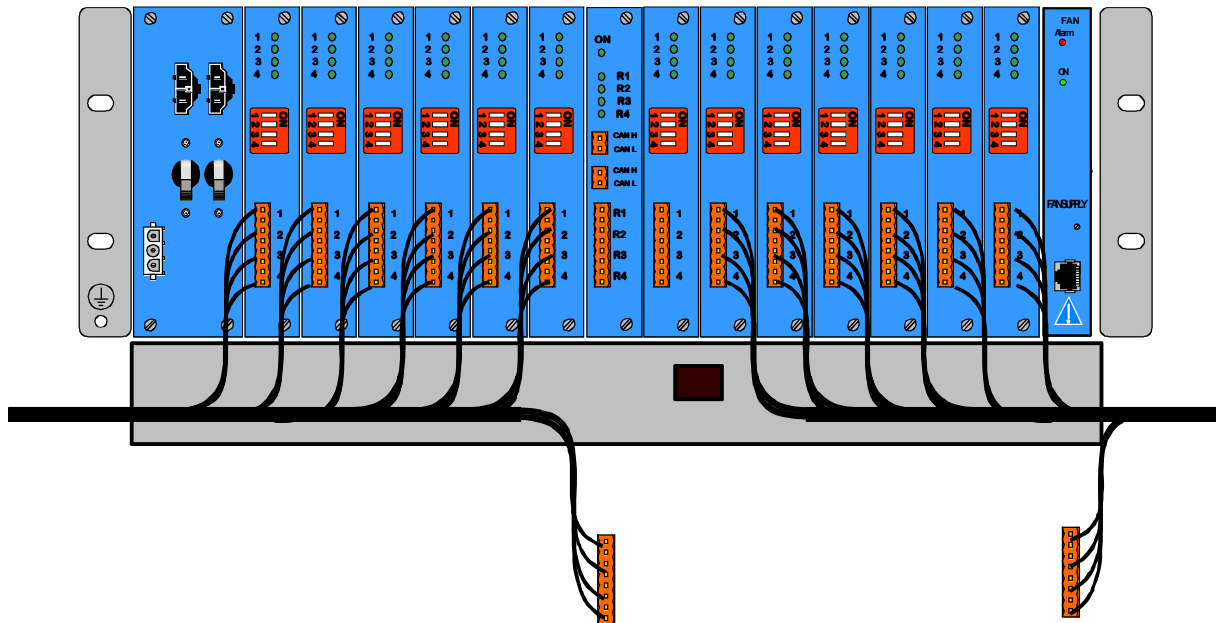

Figure 18 : Line outputs

WARNING :

Once in operation and when a loaded pair is connected , a DC HIGH VOLTAGE (320V) is present on the Line Output connectors.

The maximum current is 58mA.

If the line is not connected to the output of the up converter or if the line is open, the voltage is automatically reduced to typ. 50V.

The maximum current is 58mA.

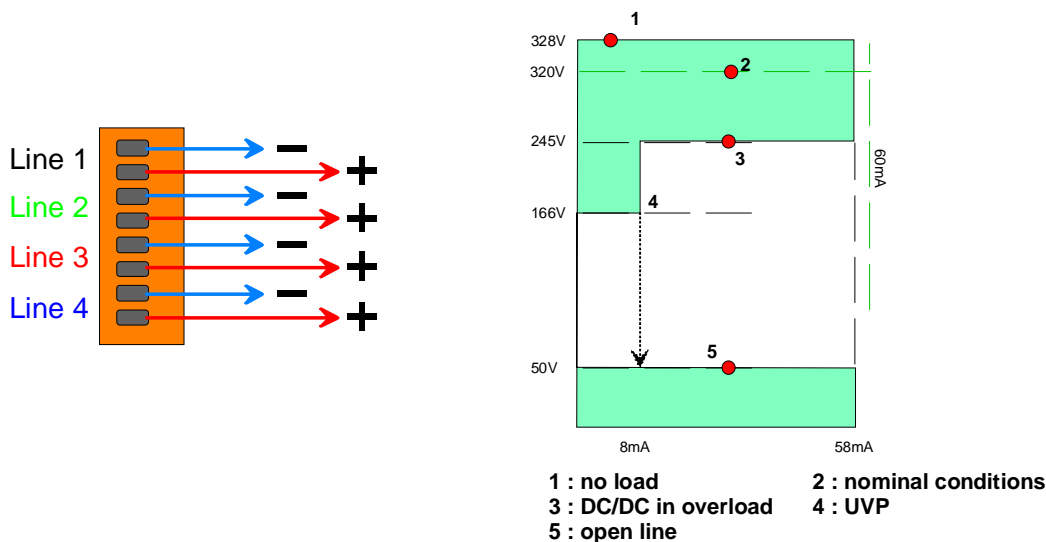

Figure 19 : DC/DC output characteristic – per line

5.3.5 DC Inputs

Description with the delivered input cables

The input unit has two identical inputs : 1 and 2 but the system can operate with only one input.

Input protections :

maximum current : breaker of 40A
 polarity : protected against wrong polarity by a series diode in the negative line
 UVP : 30V DC

Nominal voltage : - 54V (40 .. 72V) – “ + ” is the common line

IMPORTANT :

for Safety requirements , the “ + ” MUST be connected to the earth by the user

WARNING

An external disconnect and protection device “F” must be provided by the end-user

This device “F” MUST be placed in the NEGATIVE DC line.

Value : $30A \leq F \leq 40 A / 72V DC$, recommended value : 32A

Even if the two inputs A & B are used , both DC lines must be protected by the same protection device of

$30A \leq F \leq 40 A / 72V DC$, recommended value : 32A

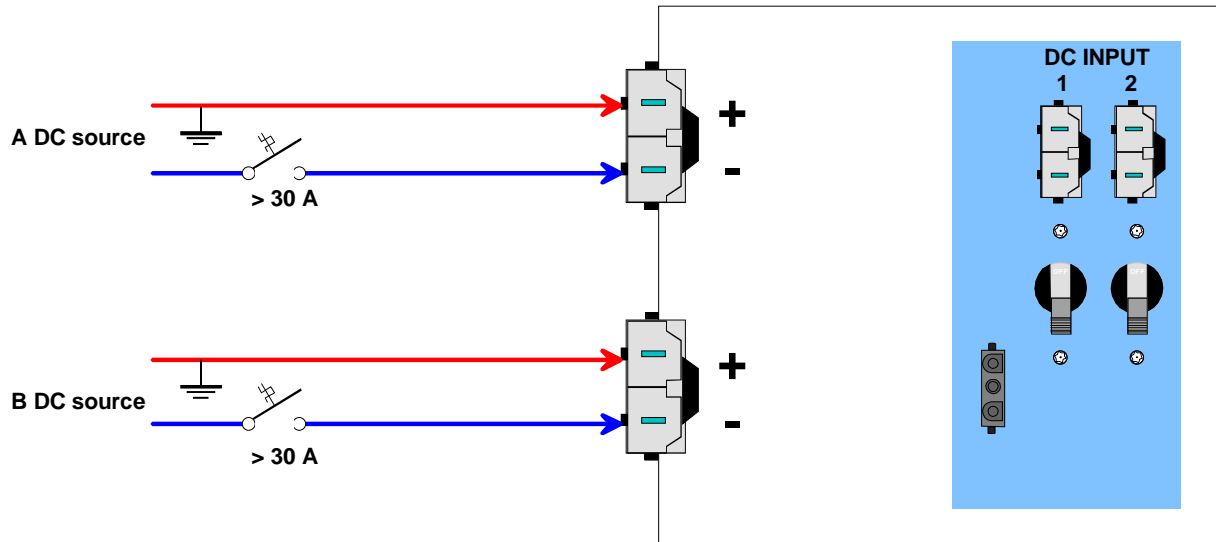

Figure 20 : input DC external protection

5.3.6 Safety of the system & assessments

- f) The voltage of the RFT-C circuit is 320 VDC.
- g) The effective line output capacitance of the Feeder is :
 - between the connection points for the conductor of the TELECOMMUNICATION NETWORK : typically 220nF
 - between the connection point for the one conductor of the TELECOMMUNICATION NETWORK and earth : typically 4nF
- h) At the time of installation, a system assessment shall be carried out to ensure that the effective capacitance of the total system, including the capacitance of the Feeder, does not exceed the values specified in EN60950-21 Figure 3.
- i) At the time of installation, it shall be checked that the voltage rating of the wiring of the TELECOMMUNICATION NETWORK is adequate for the normal RFT-C CIRCUIT voltage (320VDC)
- j) At the time of installation, it shall be checked that the circuits to be connected together are all RFT-C CIRCUITS.

CHAPTER 6 USE OF THE SYSTEM

General : only qualified Service Technicians , aware of the hazards involved , can have access to the wires / cables of the Remote Feeding Circuits

6.1 Settings – Normal operation

6.1.1 DC/DC Up converter

* DC/DC Up converters :

Four Green Leds (1 – 2 – 3 – 4) on each converter are ON

ACTIVE line

The connected and used lines must be activated by setting the corresponding dip-switch in the ON position.

NOT USED Outputs

The not used lines must be inhibited by setting the corresponding dip-switch in the OFF position.

The output is OFF and the Alarm is inhibited .

When the output is OFF , the output voltage is 0V

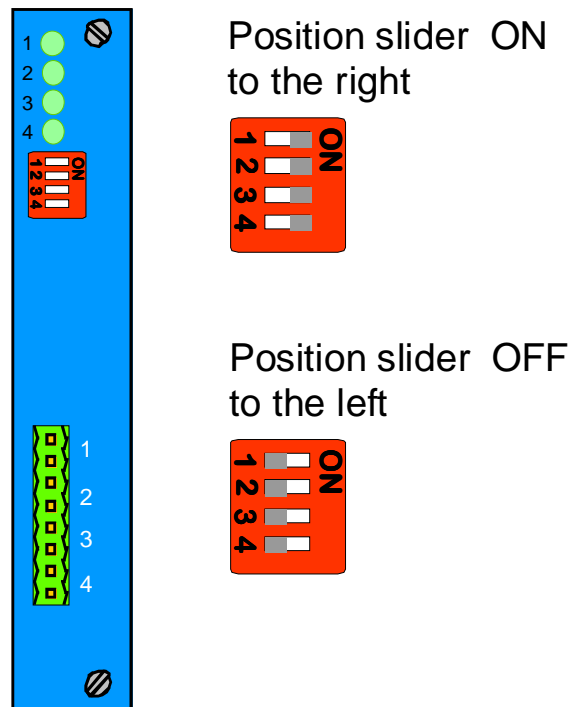

Figure 21 : Up converter

6.1.2 Controller CEM03

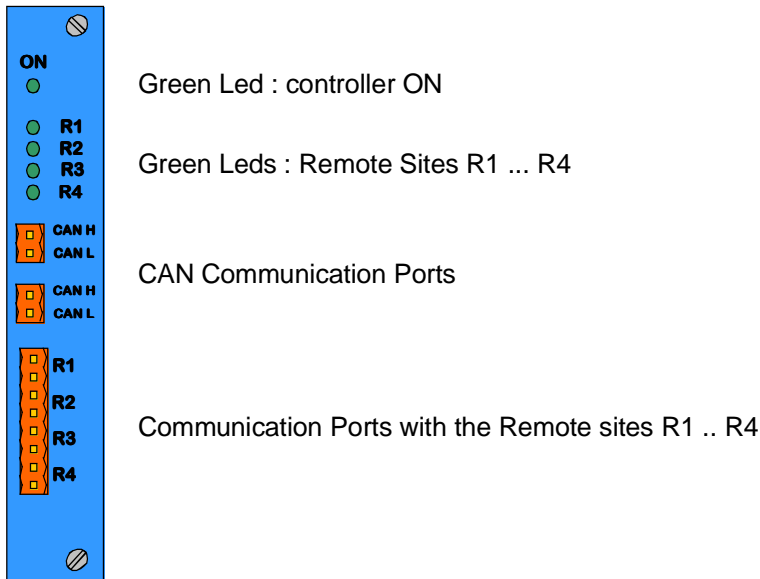
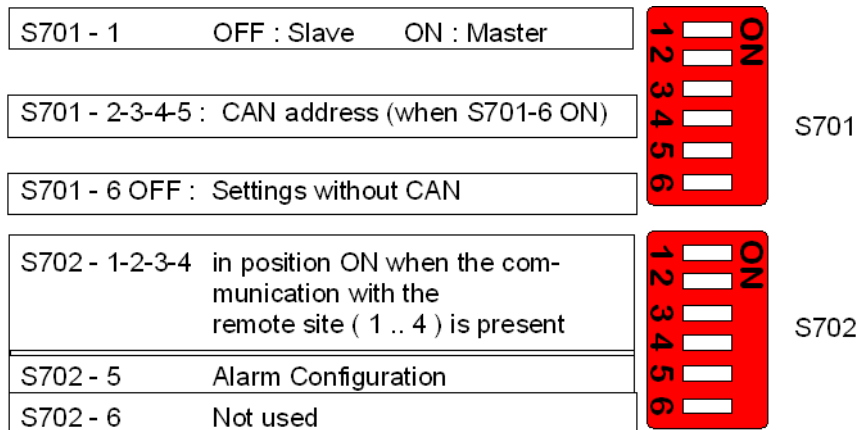

Figure 22 : CEM03 controller

- Remove the Controller to have access to the settings
- Settings with the dip-switches S701 and S702



- S701 - 1 : one controller present : **'Master'**
more then one controller preset : only ONE **'Master'** , the other as **'Slave'**
- S701 (2 .. 5) : no function (when the CAN communication is not used)
- S701 - 6 : without CAN : OFF
with CAN : ON
- S702 (1 .. 4) : one controller can receive the alarm signal from max. 4 remote sites.
when the alarm pair from the remote site is connected , place the corresponding switch in the **'ON'** position
- S701 - 5 : Alarm Configuration for the **UA** (Urgent alarm)
ON alarm in more than one unit (DC/DC , fan)
OFF more than one DC/DC converter alarm in the same unit

6.2 Overview alarms on system level

Failure	Urgent AI	Non-Urgent AI	Possible causes
1 line fail		X	open line
> 1 line fail	X		line overloaded asymmetrical Line load
DC/DC fail	X		DC/DC unit
1 fan fail		X	Defect fan
> 1 fan fail	X		Defect fans Defect fan unit

Table 6 : alarm conditions



























Explanation		CEM03			DC / DC 1 .. 4			FAN		
Status Led	LED	Leds	Status	Cause	Led 1 .. 4	Status	Cause	Leds Alarm/ On	Status	Cause
		ON 	No DC	Unit defect		DC/DC set = off		Alarm On  		Unit defect or no DC
OFF		ON G 	Unit OK		G 	No alarm		Alarm On  	No Alarm	
ON	  					Alarm	open line OR line overload OR asymmetrical line load			
		R1 	Site not set					Alarm  	Alarm U	>1 fan fail
		R1 G 	Site OK					Alarm 	Alarm NU	1 fan fail
		R1 O 	Site 1 NUA							
		R1 R 	Site 1 UA							
		R1  	Com lost							
		R1  	Com Conf ig error							
Blinking	 									

Table 7 : overview Alarms - Leds

6.3 Replacement of units

6.3.1 Replacement DC/DC converter

If defect , the DC/DC unit can be removed from the rack during operation.

Procedure :

IMPORTANT : if a DC/DC is removed from the system for a longer time (more than 3 hours) , the empty location **MUST** be filled in with a blind panel ; reference : 5304 500 06211.

After replacement , set the dip switches of the front-plate in the correct position :

- ON connected and used line
- OFF non used line

6.3.2 Replacement of the Controller CEM03

1. If defect , the CEM03 unit can be removed from the rack during operation
2. When the unit is removed , the alarm contacts are :

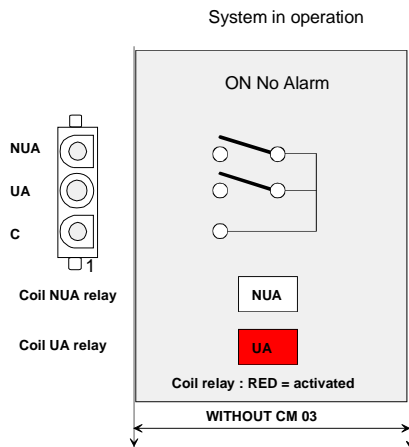

Figure 23 : alarm status CEM03 removed

3. Place the dip-switches in the same position as on the replaced unit
4. Place the unit and fix it

4.1.1 Replacement Fan Supply

See 5.1.1

If defect , the fan supply unit can be removed from the rack during operation.

Important Warning

When the Fan supply is removed, the new unit must be immediately replaced and the fan tray connected to the Fan card. There is a risk of overheating if the fan tray is not supplied when fixed under the Rack

CHAPTER 7 SHORT FORM INSTALLATION MANUAL

7.1 General

7.1.1 Safety

The output voltage of the RFT-C circuit is 320 VDC.
Refer to the section 3.1.2

7.1.2 Dimensioning of the Remote system



The number of required pairs is depending on the following parameters :

1. Power of the Remote site
2. Length of the pairs between the Central office and the Remote site
3. Cross-section of the copper pairs
4. Required redundancy

For a complete calculation of the system , please contact your Local Mitra E&I Sales Organization or the Headquarter of Mitra E&I : mail@mitra-ei.com or +32 10 438 211

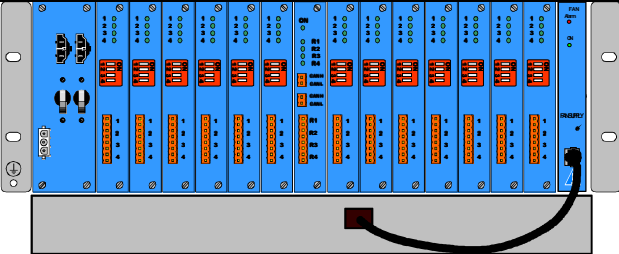
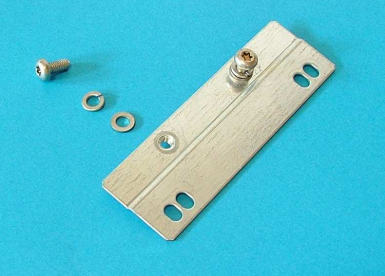
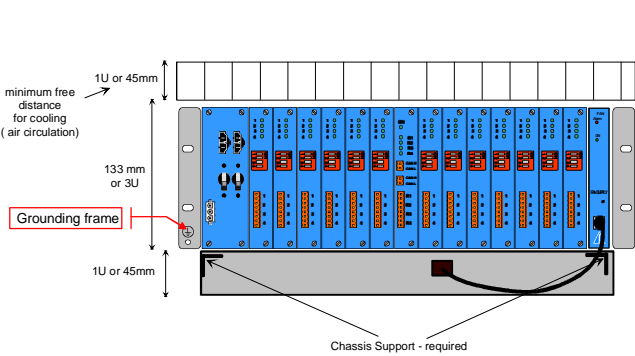
7.2 Installation procedure and check list

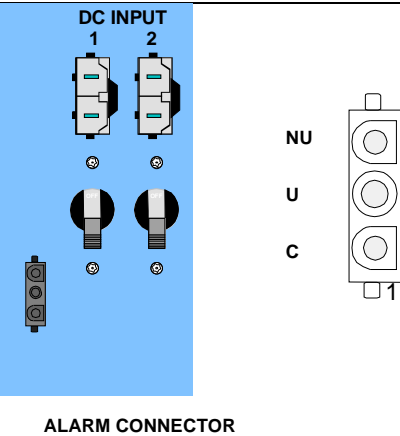
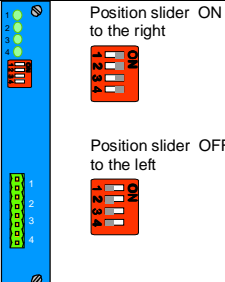
Step	Action	Comment	Picture	Refer to	Done or OK	
1.	Mount the an Tray under the rack	If not mounted on delivery		5.1.3.1	◇	
2.	Mount the ETSI brackets	19" on delivery, ETSI is optional		5.1.4	◇	
3.	Place the chassis support in the cabinet			5.1.2 or 5.1.3.2	◇	
4.	Place and fix the rack				◇	
5.	Connect the frame to the chassis ground (bonding)				5.3.1	◇
6.	Place the Fan supply unit	Most right position			5.1.3.1	◇
7.	Make the connection between Fan Tray and the Fan Supply Unit (RJ45)				5.1.3.1 & 5.2.2	◇
8.	Mount the required Converter units	Calculation of the required number of lines : refer to 7.1.2		5.2.1 & 5.2.3 & 5.3.4	◇	
9.	Mount the required CEM03 unit(s)			5.2.4	◇	
10.	Mount blind panels in the empty slots				◇	

Step	Action	Comment	Picture	Refer to	Done or OK								
11.	Open the Input breaker(s)		 <p>DC INPUT 1 2</p> <p>NU U C</p> <p>ALARM CONNECTOR</p>	5.3.5	◇								
12.	Place the DC Input connector(s)			5.3.5	◇								
13.	Place the Alarm connector			5.3.5	◇								
14.	Determine the lines configuration				◇								
15.	Connect the lines to the Up converters				◇								
16.	On the Up converter : activate the connected line(s)		 <p>Position slider ON to the right</p> <p>Position slider OFF to the left</p>	6.1.1	◇								
17.	Settings on the CEM03	Master or Slave	<table border="1"> <tr> <td>S701 - 1</td> <td>OFF : Slave</td> <td>ON : Master</td> </tr> </table> 	S701 - 1	OFF : Slave	ON : Master	6.1.2	◇					
S701 - 1	OFF : Slave	ON : Master											
18.	Settings on the CEM03	Alarm config	<table border="1"> <tr> <td>S701 - 2-3-4-5 :</td> <td>CAN address (when S701-6 ON)</td> </tr> </table>	S701 - 2-3-4-5 :	CAN address (when S701-6 ON)	6.1.2	◇						
S701 - 2-3-4-5 :	CAN address (when S701-6 ON)												
19.	Settings on the CEM03	Remote site 1-2-3-4	<table border="1"> <tr> <td>S701 - 6</td> <td>OFF : Settings without CAN</td> </tr> <tr> <td>S702 - 1-2-3-4</td> <td>in position ON when the communication with the remote site (1 .. 4) is present</td> </tr> <tr> <td>S702 - 5</td> <td>Alarm Configuration</td> </tr> <tr> <td>S702 - 6</td> <td>Not used</td> </tr> </table> 	S701 - 6	OFF : Settings without CAN	S702 - 1-2-3-4	in position ON when the communication with the remote site (1 .. 4) is present	S702 - 5	Alarm Configuration	S702 - 6	Not used	6.1.2	◇
S701 - 6	OFF : Settings without CAN												
S702 - 1-2-3-4	in position ON when the communication with the remote site (1 .. 4) is present												
S702 - 5	Alarm Configuration												
S702 - 6	Not used												
20.	Connect the Communication line(s) on the CEM03				◇								
21.	Connect all lines to the corresponding Up converters				◇								
22.	Switch ON the DC input(s)			5.3.5	◇								
23.		<p><i>The system is operational if the Remote Site is connected to the Central Office system through the dedicated pairs</i></p>											